Introduction to Fill and Backfill for Structures

Course No: G04-007

Credit: 4 PDH

J. Paul Guyer, P.E., R.A., Fellow ASCE, Fellow AEI



Continuing Education and Development, Inc.
22 Stonewall Court
Woodcliff Lake, NJ 07677

P: (877) 322-5800
info@cedengineering.com

An Introduction to Fill and Backfill for Structures



Guyer Partners
44240 Clubhouse Drive
El Macero, CA 95618
(530)758-6637
jpguyer@pacbell.net

J. Paul Guyer, P.E., R.A.

Paul Guyer is a registered civil engineer, mechanical engineer, fire protection engineer, and architect with over 35 years experience in the design of buildings and related infrastructure. For an additional 9 years he was a senior advisor to the California Legislature on infrastructure and capital outlay issues. He is a graduate of Stanford University and has held numerous national, state and local positions with the American Society of Civil Engineers, National Society of Professional Engineers and Architectural Engineering Institute.

CONTENTS

1. INTRODUCTION
2. FILL
 - 2.1 TYPES OF FILL
 - 2.2 FOUNDATIONS ON COMPACTED FILLS
 - 2.3 COMPACTION REQUIREMENTS
 - 2.4 PLACING AND CONTROL OF BACKFILL
 - 2.5 FILL SETTLEMENTS
 - 2.6 HYDRAULIC FILLS
3. BACKFILL
 - 3.1 INTRODUCTION
 - 3.2 PLANNING AND DESIGN OF STRUCTURES AND EXCAVATIONS TO ACCOMMODATE BACKFILL OPERATIONS
 - 3.3 EVALUATION, DESIGN AND PROCESSING OF BACKFILL MATERIALS
 - 3.4 SELECTION OF BACKFILL MATERIALS
 - 3.5 PROCESSING OF BACKFILL MATERIALS

This course is adapted from the *Unified Facilities Criteria* of the United States government, which is in the public domain, is authorized for unlimited distribution, and is not copyrighted.

The Figures, Tables and Symbols in this document are in some cases a little difficult to read, but they are the best available. **DO NOT PURCHASE THIS COURSE IF THE FIGURES, TABLES AND SYMBOLS ARE NOT ACCEPTABLE TO YOU.**

1. INTRODUCTION

This course is an introduction to fill and backfill for structures.

2. FILL

2.1 TYPES OF FILL. Fills include conventional compacted fills; hydraulic fills; and uncontrolled fills of soils or industrial and domestic wastes, such as ashes, slag, chemical wastes, building rubble, and refuse. Properly placed compacted fill will be more rigid and uniform and have greater strength than most natural soils. Hydraulic fills may be compacted or uncompacted and are an economical means of providing fill over large areas. Except when cohesionless materials (i.e., clean sands and gravels) are placed under controlled conditions so silty pockets are avoided and are compacted as they are placed, hydraulic fills will generally require some type of stabilization to ensure adequate foundations.

Uncontrolled fills are likely to provide a variable bearing capacity and result in a non-uniform settlement. They may contain injurious chemicals and, in some instances, may be chemically active and generate gases that must be conducted away from the structure. Perform detailed investigations of foundations on fills of the second and third groups (and the first group if not adequately compacted) to determine their suitability for supporting a structure, or else they should be avoided. Unsuitable fills often can be adequately stabilized.

2.2 FOUNDATIONS ON COMPACTED FILLS

2.2.1 COMPACTED FILL BENEATH FOUNDATIONS. Compacted fills are used beneath foundations where it is necessary to raise the grade of the structure above existing ground or to replace unsatisfactory surface soils. Fills constructed above the natural ground surface increase the load on underlying soils, causing larger settlements unless construction of the structure is postponed until fill induced settlements have taken place. If computed settlements are excessive, consider surcharging and

postponing construction until the expected settlement under the permanent fill loading has occurred. Extend the fill well beyond the loading area, except where the fill is placed against a cut slope. Where the fill is relatively thick and is underlain by soft materials, check its stability with respect to deep sliding. If the fill is underlain by weaker materials, found the footings on the fill unless settlement is excessive. If the fill is underlain by a stronger material, the footings may be founded on the fill or on the stronger material.

2.2.2 FOUNDATIONS PARTIALLY ON FILL. Where a sloping ground surface or variable foundation depths would result in supporting a foundation partially on natural soil, or rock, and partially on compacted fill, settlement analyses are required to estimate differential settlements. In general, a vertical joint in the structure should be provided with suitable architectural treatment at the juncture between the different segments of foundations. The subgrade beneath the portions of foundations to be supported on natural soils or rock should be undercut about 1 meter (3 feet) and replaced by compacted fill that is placed at the same time as the fill for the portions to be supported on thicker compacted fill.

2.2.3 DESIGN OF FOUNDATIONS ON FILL. Foundations can be designed on the basis of bearing capacity and settlement calculations. The settlement and bearing capacity of underlying foundation soils also should be evaluated. Practically all types of construction can be founded on compacted fills, provided the structure is designed to tolerate anticipated settlements and the fill is properly placed and compacted. Good and continuous field inspection is essential.

2.2.4 SITE PREPARATION. The site should be prepared by clearing and grubbing all grass, trees, shrubs, etc. Save as many trees as possible for environmental considerations. Strip and stockpile the topsoil for later landscaping of fill and borrow areas. Placing and compacting fills should preferably be done when the area is still unobstructed by footings or other construction. The adequacy of compacted fills for supporting structures is dependent chiefly on the uniformity of the compaction effort. Compaction equipment generally can be used economically and efficiently only on large

areas. Adverse weather conditions may have a pronounced effect on the cost of compacted fills that are sensitive to placement moisture content, e.g., on materials having more than 10 to 20 percent finer than the No. 200 sieve, depending on gradation.

2.2.5 SITE PROBLEMS. Small building areas or congested areas where many small buildings or utility lines surround the site, present difficulties in regard to maneuvering large compaction equipment. Backfilling adjacent to structures also presents difficulties, and power hand-tamping equipment must be employed, with considerable care necessary to secure uniform compaction.

2.3 COMPACTION REQUIREMENTS

2.3.1 GENERAL. Guidelines for selecting compaction equipment and for establishing compaction requirements for various soil types are given in Table 2-1. When fill materials have been thoroughly investigated and there is ample local experience in compacting them, it is preferable to specify details of compaction procedures, such as placement water content, lift thickness, type of equipment, and number of passes. When the source of the fill or the type of compaction equipment is not known beforehand, specifications should be based on the desired compaction results, with a specified minimum number of coverage of suitable equipment to assure uniformity of compacted densities.

2.3.2 COMPACTION SPECIFICATIONS. For most projects, the placement water content of soils sensitive to compaction moisture should be within the range of - 1 to + 2 percent of optimum water content for the field compaction effort applied. Each layer is compacted to not less than the percentage of maximum density specified in Table 2-2. It is generally important to specify a high degree of compaction in fills under structures to minimize settlement and to ensure stability of a structure. In addition to criteria set forth above, consider the following factors in establishing specific requirements:

- The sensitivity of the structure to total and differential settlement as related to structural design is particularly characteristic of structures to be founded partly on fill and partly on natural ground.
- If the ability of normal compaction equipment to produce desired densities in existing or locally available materials within a reasonable range of placement water content is considered essential, special equipment should be specified.
- The compaction requirements for clean, cohesionless, granular materials will be generally higher than those for cohesive materials, because cohesionless materials readily consolidate, or liquefy, when subjected to vibration. For coarse-grained, well-graded, cohesionless soils with less than 4 percent passing the 0.075 Micron (No. 200) sieve, or for poorly graded cohesionless soils with less than 10 percent, the material should be compacted at the highest practical water content, preferably saturated. Compaction by vibratory rollers generally is the most effective procedure. Experience indicates that pervious materials can be compacted to an average relative density of 85 ± 5 percent with no practical difficulty. For cohesionless materials, stipulate that the fill be compacted to either a minimum density of 85 percent relative density or 95 percent of compaction effort, whichever gives the greater density.
- If it is necessary to use fill material having a tendency to swell, the material should be compacted at water contents somewhat higher than optimum and to no greater density than required for stability under proposed loadings (Table 2-1). The bearing capacity and settlement characteristics of the fill under these conditions should be checked by laboratory tests and analysis. Swelling clays can, in some instances, be permanently transformed into soils of lower plasticity and swelling potential by adding a small percentage of hydrated lime.

2.3.3 COMPACTED ROCK. Compacted crushed rock provides an excellent foundation fill. Vibratory rollers are preferable for compacting rock. Settlement of fill

under the action of the roller provides the most useful information for determining the proper loose lift thickness, number of passes, roller type, and material gradation. Compaction with an 89 kN (10-ton) vibratory roller is generally preferable. The rock should be kept watered at all times during compaction to prevent collapse settlement on loading and first wetting. As general criteria for construction and control testing of rock fill are not available, test fills should be employed where previous experience is inadequate and for large important rock fills.

2.4 PLACING AND CONTROL OF BACKFILL. Backfill should be placed in lifts no greater than shown in Table 2-1, preferably 200 mm (8 inches) or less and depending on the soil and type of equipment available. No backfill should be placed that contains frozen lumps of soil, as later thawing will produce local soft spots. Do not place backfill on muddy, frozen, or frost-covered ground.

2.5 FILL SETTLEMENTS. A fill thickness of even 1 m (3 ft) is a considerable soil load, which will increase stresses to a substantial depth (approximately $2B$, where B represents the smallest lateral dimension of the fill). Stress increases from the fill may be larger than those from structure footings placed on the fill. Use procedures outlined in Chapter 10 to obtain expected settlements caused by fill loading. Many fills are of variable thickness, especially where an area is landscaped via both cutting and filling to obtain a construction site. In similar cases, attention should be given to building locations with respect to crossing cut and fill lines so that the proper type of building settlement can be designed (building may act as a cantilever, or one end tends to break off, or as a beam where the interior sags). Proper placing of reinforcing steel in the wall footings (top for cantilever action or bottom for simple beam action) may help control building cracks where settlement is inevitable; building joints can be provided at critical locations if necessary.

2.6 HYDRAULIC FILLS. Hydraulic fills are placed on land or underwater by pumping material through a pipeline from a dredge or by bottom dumping from barges. Dredge materials vary from sands to silts and fine-grained silty clays and clays. Extensive

maintenance dredging in the United States has resulted in disposal areas for dredge materials, which are especially attractive from an economic standpoint for development purposes. Dikes are usually required to retain hydraulic fills on land and may be feasible for underwater fills. Underwater dikes may be constructed of large stones and gravel.

2.6.1 PERVIOUS FILLS. Hydraulically placed pervious fills with less than 10 percent fines will generally be at a relative density of 50 to 60 percent but locally may be lower. Controlled placement is necessary to avoid silt concentrations. Compaction can be used to produce relative densities sufficient for foundation support (Table 2-1). Existing uncompacted hydraulic fills of pervious materials in seismic areas are subject to liquefaction, and densification will be required if important structures are to be founded on such deposits. Rough estimates of relative density may be obtained using standard penetration resistance. Undisturbed borings will be required to obtain more precise evaluation of in situ density and to obtain undisturbed samples for cyclic triaxial testing, if required. For new fills, the coarsest materials economically available should be used. Unless special provisions are made for removal of fines, borrow containing more than 10 percent fines passing the 0.075 Micron (No. 200) sieve should be avoided, and even then controlled placement is necessary to avoid local silt concentrations.

2.6.2 FINE-GRAINED FILLS. Hydraulically placed overconsolidated clays excavated by suction dredges produce a fill of clay balls if fines in the wash water are permitted to run off. The slope of such fills will be extremely flat ranging from about 12 to 16H on 1V. These fills will undergo large immediate consolidation for about the first 6 months until the clay balls distort to close void spaces. Additional settlements for a one-year period after this time will total about 3 to 5 percent of the fill height. Maintenance dredgings and hydraulically placed normally consolidated clays will initially be at water contents between 4 and 5 times the liquid limit. Depending on measures taken to induce surface drainage, it will take approximately 2 years before a crust is formed sufficient to support light equipment and the water content of the underlying materials approaches the liquid limit. Placing 305 mm to 1 m (1 to 3 ft) of additional cohesionless borrow can be used to improve these areas rapidly so that they can support surcharge fills, with or without

vertical sand drains to accelerate consolidation. After consolidation, substantial one- or two-story buildings and spread foundations can be used without objectionable settlement. Use considerable care in applying the surcharge so that the shear strength of the soil is not exceeded (e.g., use light equipment).

2.6.3 SETTLEMENTS OF HYDRAULIC FILLS. If the coefficient of permeability of a hydraulic fill is less than 0.0616 mm/minute (0.0002 ft/minute), the consolidation time for the fill will be long and prediction of the behavior of the completed fill will be difficult. For coarse-grained materials with a larger coefficient of permeability, fill consolidation and strength buildup will be relatively rapid and reasonable strength estimates can be made. Where fill and foundation soils are fine-grained with a low coefficient of permeability, piezometers should be placed both in the fill and in the underlying soil to monitor pore pressure dissipation. It may also be necessary to place settlement plates to monitor the settlement. Depending on the thickness of the fill, settlement plates may be placed both on the underlying soil and within the fill to observe settlement rates and amounts.

2.6.4 COMPACTION OF HYDRAULIC FILLS. Dike-land hydraulic fills can be compacted as they are placed by use of the following:

- Driving track-type tractors back and forth across the saturated fill. (Relative densities of 70 to 80 percent can be obtained in this manner for cohesionless materials.)
- Other methods such as vibratory rollers, vibro-flotation, terraprobings, and compaction piles. Below water, hydraulic fills can be compacted by the use of terraprobings, compaction piles, and blasting.

2.6.5 UNDERWATER HYDRAULIC FILLS. For structural fill placed on a dredged bottom, remove the fines dispersed in dredging through a final sweeping operation, preferably with suction dredges, before placing the fill. To prevent extremely flat slopes at the edge of a fill, avoid excessive turbulence during dumping of the fill material by placing with clamshell or by shoving off the sides of deck barges. To obtain relatively

steep slopes in underwater fill, use mixed sand and gravel. With borrow containing about equal amounts of sand and gravel, underwater slopes as steep as 1V on 2H may be achieved by careful placement. Uncontrolled bottom dumping from barges through great depths of water will spread the fill over a wide area. To confine such fill, provide berms or dikes of the coarsest available material or stone on the fill perimeter.

3. BACKFILL

3.1 INTRODUCTION. The greatest deficiencies in earthwork operations around deep-seated or subsurface structures occur because of improper backfilling procedures and inadequate construction control during this phase of the work. Therefore, primary emphasis in this section is on backfilling procedures. Design and planning considerations, evaluation and selection of materials and other phases of earthwork construction are discussed where pertinent to successful backfill operations. Although the information in this section is primarily applicable to backfilling around large and important deep-seated or buried structures, it is also applicable in varying degrees to backfilling operations around all structures, including conduits.

3.2 PLANNING AND DESIGN OF STRUCTURES AND EXCAVATIONS TO ACCOMMODATE BACKFILL OPERATIONS. Many earthwork construction problems can be eliminated or minimized through proper design, thorough planning, and recognition of problem areas effecting backfill operations. Recognition and consideration must be given in planning to design features that will make backfilling operations less difficult to accomplish. Examples of problem areas and how forethought in design and planning can help to eliminate backfill deficiencies are presented in the following paragraphs.

3.2.1 EFFECT OF EXCAVATION AND STRUCTURAL CONFIGURATION ON BACKFILL OPERATIONS. Some of the problems encountered in earthwork construction are related to the excavation and the configuration of the structures around which backfill is to be placed. It is the designer's responsibility to recognize these

problems and to take the necessary measures to minimize their impact on the backfill operations.

3.2.1.1 OPEN ZONES. An open zone is defined as a backfill area of sufficient dimensions to permit the operation of heavy compaction equipment without endangering the integrity of adjacent structures around which compacted backfill operations are conducted. In these zones where large compaction equipment can operate, it is generally not too difficult to obtain the desired density if appropriate materials and proper backfill procedures are used. For areas that can be economically compacted by heavy equipment, the designer can avoid problems by including in the design provisions sufficient working space between structures or between excavation slopes and structures to permit access by the heavy compaction equipment. Generally, a working space of at least 3.6 m (12 ft) between structure walls and excavation slope and at least 4.5 m (15 ft) between structures is necessary for heavy equipment to maneuver. In addition to maneuvering room, the designer must also consider any adverse loading caused by the operation of heavy equipment too close to the structure walls.

Soil Group	Soil Types	Degree of Compaction	Fill and Backfill					Deep Foundation Deposits		
			Typical Equipment	Typical Equipment and Procedures for Compaction			Field Control	Compaction Methods	Field Control	
				No. of Phases or Coverages	Comp. Lift Thick., mm (in)	Placement Water Content				
Pervous (Free Draining)	GW GP SW SP	90 to 95% ASTM D 1557 maximum density 75 to 85% of relative density	Vibratory rollers and compactors Rubber tired rollers ^a Crawler type tractor ^b Power hand tamper ^c	Indefinite	Indefinite	Saturate by flooding	Control samples at intervals to determine degree of compaction or relative density	None available except for near surface (down to approximate depth of five feet) Compaction by equipment and procedure shown at left		
				2-5 coverages	300 (12)					
		85 to 90% ASTM D 1557 maximum density 65 to 75% of relative density	Semi compacted	Rubber tired roller ^a Crawler type tractor Power hand tamper	Indefinite	360 (14)	Saturate by flooding	Control samples per above, if needed	Vibrofloatation, compaction piles, sand piles, explosives Surface compaction as per above	Undisturbed samples from borings or test pits to determine degree of compaction or relative density
					1-2 coverages	250 (10)				
					Indefinite	200 (8)				
				Controlled routing of construction equipment	Indefinite	200 - 250 (8-10)				

Table 2-1
A Summary of Densification Methods for Building Foundations

Soil Group	Soil Types	Degree of Compaction	Fill and Backfill						Deep Foundation Deposits		
			Typical Equipment and Procedures for Compaction						Field Control	Compaction Methods	Field Control
			Equipment	No. of Passes or Coverages	Lift Thick., mm (in)	Placement Water Content					
Semi-Imperious and Imperious	GM	90 - 95% ASTM D 1557 maximum density Compacted	Rubber tired roller (a)	2-5 coverages	200 (8)	Optimum water content based on ASTM D 1557	Control samples at intervals to determine degree of compaction	(A) Surface compaction by equipment and procedures shown @ left is feasible only if material is at proper water content. (B) Densification of soils is controlled by consolidation process: Preload fills* Lowering of groundwater table Drying * Consolidation may be accelerated by means of vertical drains. Field control exercised by observation of pore pressures and surface settlements.			
	GC		Sharpfoot roller (d)	4-8 passes	150 (6)						
	SM		Power hand tamper (c)	Indefinite	100 (4)						
	SC		Rubber tired roller (a)	2-4 coverages	250 (10)					(A) Optimum water content based on ASTM D 1557. (B) Wet side maximum water content at which one material can satisfactorily operate, minimum water content required to bond particles (and not result in voids or honey-combed materials.)	
	ML		Sharpfoot roller (d)	4-8 passes	200 (8)						
	CL		85-90% ASTM D 1557 maximum density Semicompacked		Crawler type tractor (b)					3 coverages	150 (6)
	OL	Power hand tamper (d)			Indefinite	150 (6)					
	OH	Control of construction equipment			Indefinite	150 - 200 (6-8)					
	MH										
	CH										

Note: The above requirements will be adequate in relation to most construction. In special cases where desirable settlements are unusually small, it may be necessary to employ additional compaction equivalent to 95-100% of CESS compaction effort. A coverage consists of one application of the wheel of a rubber tired roller or the tread of a crawler type tractor over each point in the area being compacted. For a sharpfoot roller drum over the area being compacted.

a. Rubber tired rollers having a wheel load between 18,000 lbs and 25,000 lbs, and a tire pressure between 80 and 100 psi.
b. Crawler type tractors weighing not less than 20,000 lbs and exerting a foot pressure not less than 5 1/2 psi.
c. Power hand tamper weighing more than 100 lbs; pneumatic or operated by gasoline engine.
d. Sharpfoot rollers having a foot pressure between 250 and 500 psi and bumping 7-10 lamp lengths with a face area between 7 and 16 sq. inches.

Table 2-1 (continued)
A Summary of Densification Methods for Building Foundations

ASTM D 1557 Maximum Density, in Percentage

<u>Fill/Embankment/Backfill</u>	Cohesive Soils	Cohesionless Soils
Under proposed structures, building Slabs, steps, paved areas	90	95 ^a
Under sidewalks and grassed areas	85	90
<u>Sub-grade</u>		
Under building slabs, steps and Paved areas / top 300 mm (12inches)	90	95
Under sidewalks, top 150 mm (6 inches)	85	90

^a Maybe 85% relative density / whichever is higher

Table 2-2
Compaction Density as a Percent of ASTM D 1557 Laboratory Test Density

3.2.1.2 CONFINED ZONES. Confined zones are defined as areas where backfill operations are restricted to the use of small mechanical compaction equipment either because the working room is limited or because heavy equipment would impose excessive soil pressures that could damage the structure. Most deficiencies in compacted backfill around subsurface structures have occurred in confined zones where required densities are difficult to achieve because of restricted working room and relatively low compaction effort of equipment that is too lightweight. The use of small equipment to achieve required compaction is also more expensive than heavy equipment since thinner lifts are required. However, because small compaction equipment can operate in spaces as narrow as 0.6 m (2 ft) in width, such equipment is necessary to achieve the required densities in some areas of most backfill projects. Therefore, the designer should plan structure and excavation areas to minimize the use of small compaction equipment.

3.2.2 STRUCTURE CONFIGURATION. The designer familiar with backfilling operations can avoid many problems associated with difficult-to-reach confined zones

(which are created by structural shapes obstructing the placement and compaction of backfill) by considering the impact of structural shapes on backfill operations. In most cases, structural shapes and configurations that facilitate backfill operations can be used without significantly affecting the intended use of the structure.

3.2.2.1 CURVED BOTTOM AND WALL STRUCTURES. Areas below the spring line of circular, elliptical, and similar shaped structures are difficult to compact backfill against because compaction equipment cannot get under the spring line. If possible, structures should be designed with continuously curved walls and flat floors such as in an igloo-shaped structure. For structures where a curved bottom is required to satisfy the intended function, it may be advisable for the designer to specify that a template shaped like the bottom of the structure be used to guide the excavation below the spring line so that uniform foundation support will be provided.

3.2.2.2 COMPLEX STRUCTURES. Complex structures have variable shaped walls and complex configurations in plan and number of levels. These structures can also be simple structures interconnected by access shafts, tunnels, and utility conduits. Because of their irregular shapes and configurations, the different types of structures significantly increase excavation and backfill problems. Typical examples of complex structures are stepped multilevel structures and multi-chambered structures with interconnecting corridors (Figure 3-1). Complex structures are generally more difficult to compact backfill around and are more likely to have settlement problems. Although the multilevel step structure (Figure 3-1(a)) is not particularly difficult to compact backfill around (at least for the first level) the compaction of backfill over the offset structure will generally require the use small equipment. Small equipment will also be required for compaction of backfill around and over the access corridor and between the two chambers (Figure 3-1(b)). Where possible, the design should accommodate intended functions into structures with uniformly shaped walls and a simple configuration. Where structures of complex configurations are necessary, construction of a three-dimensional model during the design and planning phases will be extremely beneficial. From the model, designers can more easily foresee and eliminate areas in which it would be difficult to place and compact backfill.

3.2.2.3 SERVICE CONDUITS. Since compaction of backfill is difficult around pipes and conduits, group utility lines together or place in a single large conduit where feasible, rather than allow to and form a haphazard maze of pipes and conduits in the backfill. Run utility lines either horizontally or vertically wherever possible. Coordinate plans for horizontally run appurtenances, such as utility lines, access tunnels, and blast-delay tubing, with the excavation plans so that wherever feasible these appurtenances can be supported by undisturbed soils rather than by compacted backfill.

3.2.2.4 EXCAVATION PLANS. Develop excavation plans with the backfill operations and the structure configurations in mind. The excavation and all completed structures within the excavation should be conducive to good backfill construction procedures, and access should be provided to all areas so that compaction equipment best suited to the size of the area can be used. The plans for excavation should also provide for adequate haul roads and ramps. Positive excavation slopes should be required in all types of soil deposits to facilitate compaction of backfill against the slope and to ensure good bond between the backfill and the excavation slopes. Remove loose material from the excavation slopes; in some case, benches may be required to provide a firm surface to compact backfill against.

3.2.2.5 LINES AND GRADES. Exercise care in planning lines and grades for excavations to ensure that uniform, adequate support is provided at the foundation level of important structures. Generally, foundations consisting of part backfill and part undisturbed materials do not provide uniform bearing and should be avoided wherever possible. The foundation should be over-excavated where necessary and backfilled with compacted select material to provide uniform support for the depth required for the particular structure. Where compacted backfill is required beneath a structure, the minimum depth specified should be at least 450 mm (18 inches).

3.2.2.6 THIN-WALLED METAL STRUCTURES. Thin-walled, corrugated metal structures are susceptible to deflections of structural walls when subjected to backfill loads. Minimize adverse deflections by planning backfill operations so that compacted backfill is brought up evenly on both sides of the structure to ensure uniform stress distribution. Temporary surcharge loads applied to the structure crown may also be required to prevent vertical distortions and inward deflection at the sides.

3.2.3 BACKFILL PROBLEM AREAS. Other features that have the potential to become problem areas are discussed in the following paragraphs. These potential problem areas must be considered during the planning and design phases to minimize deficiencies in structure performance associated with backfill placement and to make backfilling operations less difficult.

3.2.3.1 SETTLEMENT AND DOWNDRAW. In the construction of underground structures, tolerances to movement are often considerably less than those in normal construction. The design engineer must determine and specify allowable tolerances in a differential settlement and ensure that the differential settlement is minimized and/or accommodated.

3.2.3.2 CRITICAL ZONES. Critical backfill zones are those immediately beneath most structures. Consolidation and swelling characteristics of backfill materials should be thoroughly investigated so that materials having unfavorable characteristics will not be used in those zones. Some settlement can be expected to take place, but it can be minimized by requiring a higher than normal compacted density for the backfill. Cohesive backfill compacted at water content as little as 3 to 4 percentage points below optimum may result in large settlements caused by collapse of non-swelling soil material or heave of swelling materials upon saturation after construction. Compacting cohesive backfill material at optimum water content, or slightly on the wet side of optimum, will generally reduce the amount of settlement and swelling that would occur. Confirm the reduction by consolidation and swell tests on compacted specimens.

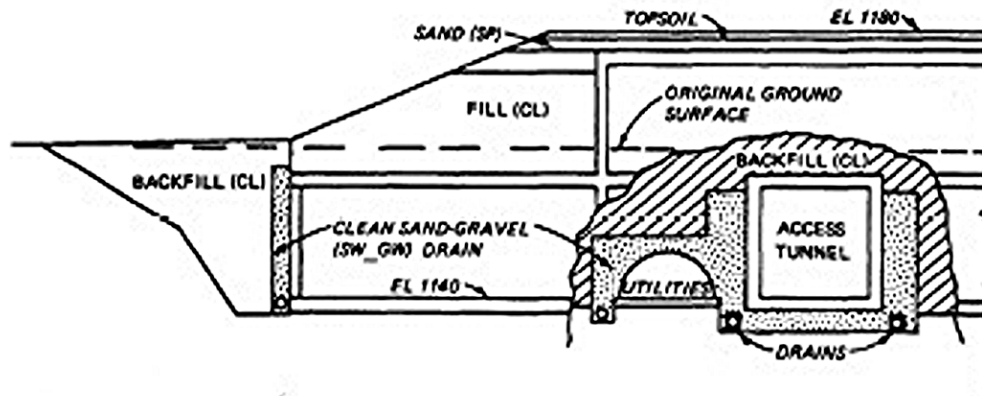

(a) TWO-STORY STRUCTURE

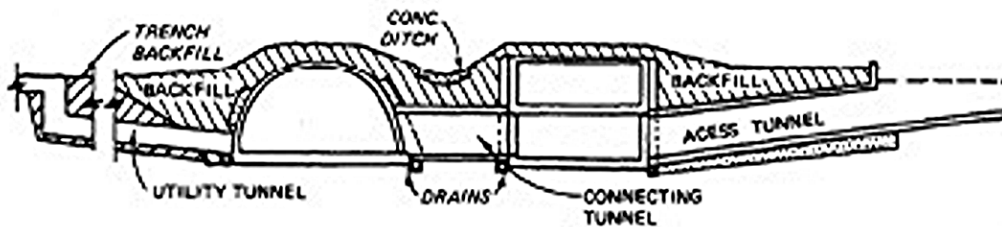

(b) CONNECTING STRUCTURES

Figure 3-1

Complex structures

3.2.3.3 SERVICE CONDUITS. Settlement within the backfill around structures will also occur. A proper design will allow for the estimated settlement as determined from studies of consolidation characteristics of the compacted backfill. Where service conduits, access corridors, and similar facilities connect to the structure oversized sleeves, flexible connections and other protective measures may be used, as appropriate, to prevent damage within the structure.

3.2.3.4 DIFFERENTIAL SETTLEMENT. Complex structures are more susceptible to differential settlement because of the potential for large variations in loads carried by each component foundation. In the multilevel stepped structure (Figure 3-1(a)), the foundation supporting the lower level offset component must also support the volume of backfill over that part of the structure. Measures must be taken to ensure that the proper

functioning of all elements is not hampered by differential settlement. The increased cost of proper design and construction where unusual or difficult construction procedures are required is insignificant when compared with the cost of the structure. The cost of remedial measures to correct deficiencies caused by improper design and construction will usually be greater than the initial cost required to prevent the deficiencies.

3.2.3.5 DOWNDRAG. In addition to conventional service loads, cut and cover subsurface structures are susceptible to downdrag frictional forces between the structure and the backfill that are caused by settlement of the backfill material adjacent to and around the structure. Downdrag loads can be a significant proportion of the total vertical load acting on the structure and must be considered in the structure settlement analysis. Structure-backfill friction forces may also generate significant shear forces along the outer surface of structures with curve-shaped roofs and walls. The magnitude of the friction forces depends upon the type of backfill, roughness of the structure's surface, and magnitude of earth pressures acting against the structure. Techniques for minimizing downdrag friction forces generally include methods that reduce the structure surface roughness such as coating the structure's outer surface with asphalt or sandwiching a layer of polyethylene sheeting between the structure's outer surface and fiberboard (blackboard) panels. Backfill settlement and associated downdrag can also be minimized by requiring higher backfill densities adjacent to the structure.

3.2.3.6 GROUNDWATER. Groundwater is an important consideration in planning for construction of subsurface structures. If seepage of groundwater into the excavation is not adequately controlled, backfilling operations will be extremely difficult. The groundwater level must be lowered sufficiently (at least 0.6 to 0.9 m (2 to 3 ft) for granular soils and as much as 1.6 to 3 m (5 to 10 ft) for fine-grained soils below the lowest level of backfilling) so that a firm foundation for backfill can be established.

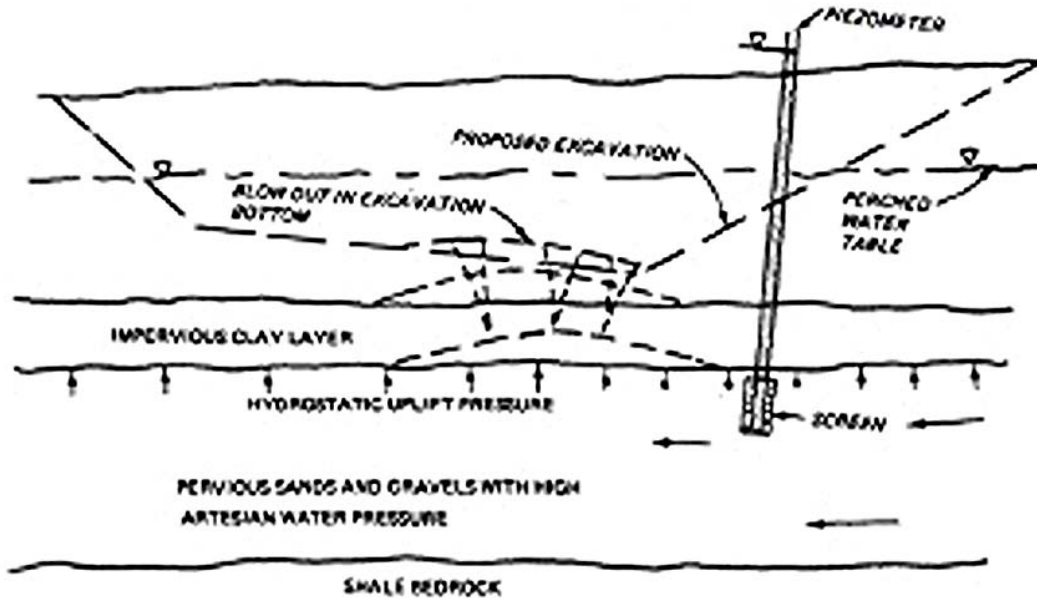

Figure 3-2
Excavation Subject to Bottom Heave

If the level is not lowered, the movement of hauling or compaction equipment may pump seepage water through the backfill, or the initial backfill layers may be difficult to compact because of an unstable foundation. Since the proper water content of the backfill is essential for achieving proper compaction, prevention of groundwater seepage into the excavation during backfilling operations is mandatory. The contractor is generally responsible for the design, installation and operation of dewatering equipment. Inadequate dewatering efforts can be minimized by adequate planning and implementation of groundwater investigations. Figure 3-2 above indicates an excavation subject to bottom heave.

- The possibility of hydraulic heave in cohesive material must also be investigated to ensure stability of the excavation floor. Hydraulic heave may occur where an excavation overlies a confined permeable stratum below the groundwater table. If the upward hydrostatic pressure acting at the bottom of the confining layer exceeds the weight of overburden between the bottom of the excavation and the confining layer, the bottom of the excavation will rise bodily

even though the design of the dewatering system is adequate for control of groundwater into the excavation. To prevent heave, the hydrostatic pressure beneath the confined stratum must be relieved

- Subsurface structures located in part or wholly below the groundwater table require permanent protection against groundwater seepage. The type of protection may range from simple impermeable barriers to complex permanent dewatering systems

3.2.3.7 GRADATION AND FILTER CRITERIA FOR DRAINAGE MATERIALS.

Groundwater control is often accomplished by ditches positioned to intercept the flow of groundwater and filled with permeable granular material. The water is generally collected in perforated pipes located at the bottom of the ditch and pumped to a suitable discharge area. Such drainage systems are referred to as filter drains. The gradation of the granular filter material is critical for the functioning of the system. Selection of the proper gradation for the filter material is dependent upon the gradation of the material that is being drained. Drainage of silts and clays usually requires a graded filter made up of several layers of granular material with each layer having specific requirements for maximum grain size and gradation.

3.2.3.7.1 SELECTED MATERIAL. If materials at the jobsite do not meet the designed filter requirements, selective material must be purchased from commercial sources and shipped to the jobsite. Filter material must be stockpiled according to gradation. For graded filter systems, the materials must be placed with care to minimize mixing of individual components.

3.2.3.7.2 FILTER CLOTHS. Both woven and non-woven filter cloths, which have been found satisfactory for use as a filter media for subsurface drains, are available. When granular filter materials are not economically available, a single wrap of filter cloth around a pipe may be used in lieu of a coarser backfill. When available granular filter material is too coarse to satisfy filter criteria for the protected soil, a single layer of filter cloth may be used adjacent to the protected soil. To reduce the chance of clogging, no filter cloth should be specified with an open area less than 4 percent and or equivalent

opening size (EOS) of less than the No. 100 sieve (0.15 mm (0.0059 inch)). A cloth with openings as large as allowable should be specified to permit drainage and prevent clogging. Filter cloth can also provide protection for excavated slopes and serve as a filter to prevent piping of fine-grained soils. In one project, sand was not available for backfill behind a wall and coarse gravel had to be used to collect seepage. The filter cloth used to protect the excavated slope served as a filter against piping of the natural silty clay under seepage gradients out of the excavated slope after the coarse gravel backfill was placed.

3.2.3.8 EARTH PRESSURES. The rationale design of any structure requires the designer to consider all loads acting on the structure. In addition to normal earth pressures associated with the effective pressure distribution of the backfill materials, subsurface cut-and-cover structures may also be subjected to surcharge loads caused by heavy equipment operating close to the structure and by increased permanent lateral earth pressures caused by compaction of backfill material with heavy equipment.

3.2.3.8.1 SURCHARGE EARTH PRESSURES. Exact solutions for surcharge earth pressures generated by heavy equipment (or other surcharge loads) do not exist. However, approximations can be made using appropriate theories of elasticity, such as Boussinesq's equations for load areas of regular shape or Newmark's charts for irregular shaped load areas. As a conservative guide, heavy-equipment surcharge earth pressures may be minimized by specifying that heavy compaction equipment maintain a horizontal distance from the structure equivalent to the height of the backfill above the structure's foundation.

3.2.3.8.2 COMPACTION INDUCED PRESSURES. Compaction-induced earth pressures can cause a significant increase in the permanent lateral earth pressures acting on a vertical wall of a structure (Figure 3-3). This diagram is based on the assumption that the equipment can operate to within 150 mm (6 in) of the wall. Significant reductions in lateral pressures occur as the closest allowable distance to the wall is increased (Figure 3-3). For an operating distance 1.5 m (5 ft) from the wall, the induced horizontal earth pressure is much less than that caused by the backfill. The magnitude of the increase in lateral pressure is dependent, among other factors, on the effective weight of the compaction equipment, earth pressure coefficient, and Poisson's

ratio of the backfill material. The designer must evaluate the economics of the extra cost of structures designed to withstand very close-in operation of heavy compaction equipment versus the extra cost associated with obtaining the required compaction of backfill in thin lifts with smaller compaction equipment. A more economical alternative might be to specify how close to the walls different weights of compaction equipment can be operated. One method of reducing lateral earth pressures behind walls has been to use about 1.2 m (4 ft) of uncompacted granular (sand or gravel) backfill above the base of the wall. Soil backfill can then be compacted in layers above the granular backfill. Compression of the granular material prevents the buildup of excessive lateral pressures against the wall.

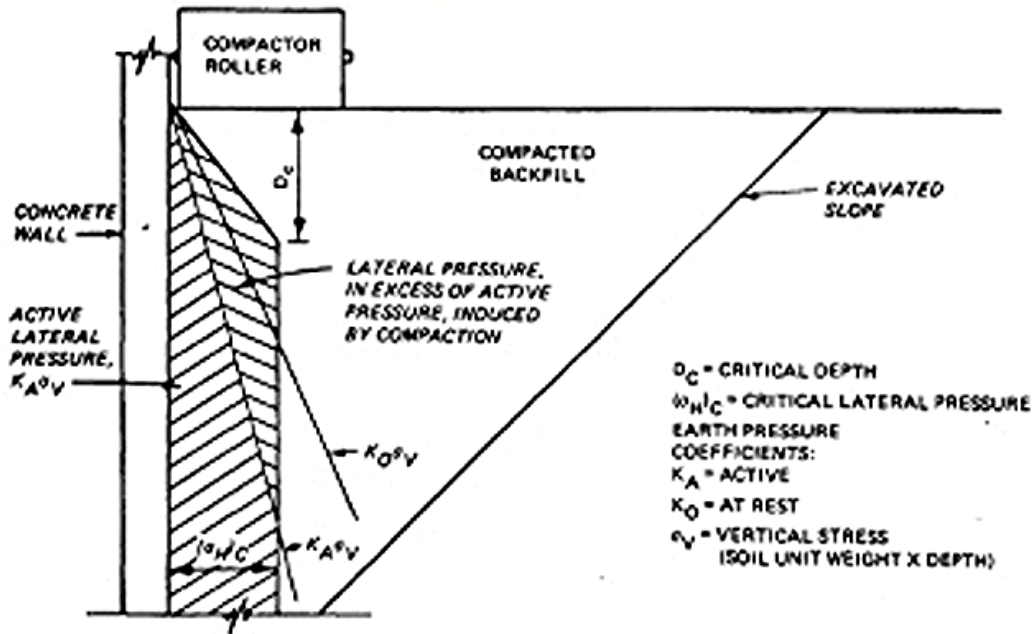

COMPACTION EQUIPMENT	CRITICAL DEPTH D_c , FT	w_{H1C} , psf
10-TON SMOOTH WHEEL ROLLER	1.9	420
32-TON VIBRATORY ROLLER	1.7	400
1.4-TON VIBRATORY ROLLER	1.2	260
400-KG VIBRATORY PLATE	1.5	340
120-KG VIBRATORY PLATE	1.0	240

a. MAXIMUM INDUCED LATERAL PRESSURES

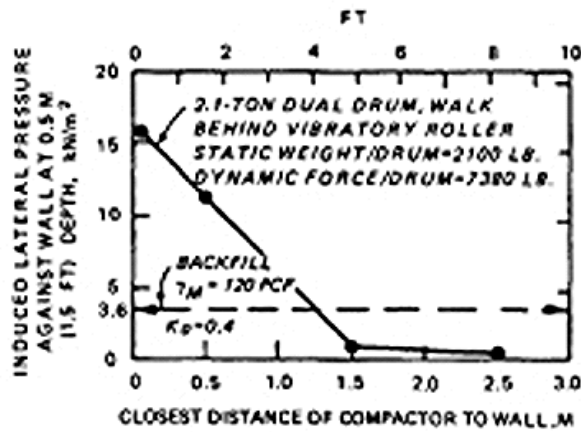

b. EFFECT OF DISTANCE FROM WALL

Figure 3-3

Excess Lateral Pressure against Vertical Walls Induced by Compaction

3.3 EVALUATION, DESIGN AND PROCESSING OF BACKFILL MATERIALS.

3.3.1 The evaluation, design and proper processing of backfill materials are extremely important phases of the pre-construction operations. The purpose of the evaluation phase is to determine the engineering characteristics of potential backfill materials. The design phase must take into account the engineering characteristics required for the backfill and specify materials that, when compacted properly, will have these characteristics. Proper processing of the backfill material will ensure that desirable engineering characteristics will be obtained as the material is placed.

3.3.2 EVALUATION OF BACKFILL MATERIALS. Evaluation of backfill materials consists of exploration, sampling and laboratory testing to determine the engineering characteristics of potential backfill materials. To emphasize the need for an adequate investigation, some aspects of planning and investigation that should be considered are discussed in the following paragraphs.

3.3.2.1 FIELD EXPLORATION AND SAMPLING. Field exploration and sampling are extremely important to the design of foundations, selection of backfill and planning for construction. A great amount of material will be available from required excavations, and the investigation for foundation conditions should include the sampling and evaluation of these materials for possible use as backfill. Where an adequate volume of suitable backfill cannot be obtained from the construction excavation, the exploration and sampling program must be expanded to find other sources of suitable material whether from nearby borrow areas or commercial sources. The purpose of the investigation is to delineate critical conditions and provide detailed information on the subsurface deposits so that proper design and construction, including backfilling operations, can be accomplished with minimum difficulty. Thus careful planning is required prior to the field exploration and sampling phase of the investigation. Available geologic and soil data should be studied, and if possible, preliminary borings should be made. Once a site has been tentatively selected, orientation of the structure to the site should be established. The engineer who plans the detailed field exploration program must have knowledge of the structure; e.g., its configuration and foundation

requirements for design loads and settlement tolerances. The planning engineer should also know the type and quantity of backfill required. The importance of employing qualified field exploration personnel cannot be overemphasized. The exploration crews should be supervised in the field by a soils engineer or geologist familiar with the foundation and backfill requirements so that changes can be made in the exploration program where necessary to provide adequate information on subsurface conditions. The field engineer should also know the location of significant features of the structure so that sampling can be concentrated at these locations. In addition, he should have an understanding of the engineering characteristics of subsurface soil and rock deposits that are important to the design of the structure and a general knowledge of the testing program so that the proper type and quantity of samples will be obtained for testing.

- From the samples, the subsurface deposits can be classified and boring logs prepared. The more continuous the sampling operation, the more accurate will be the boring logs. All borings should be logged with the description of the various strata encountered as discussed in ASTM D 1586 and ASTM D 2487. Accurate logging and correct evaluation of all pertinent information are essential for a true concept of subsurface conditions.
- When the exploratory borings at the construction site have been completed, the samples and logs of borings should be examined to determine if the material to be excavated will be satisfactory and in sufficient quantity to meet backfill requirements. Every effort should be made to use the excavated materials; however, if the excavated materials are not satisfactory or are of insufficient quantity, additional exploration should be initiated to locate suitable borrow areas. If borrow areas are not available, convenient commercial sources of suitable material should be found. Backfill sources, whether excavation, borrow or commercial, should contain several times the required volume of compacted backfill.
- Groundwater studies prior to construction of subsurface structures are of the utmost importance, since groundwater control is necessary to provide

a dry excavation in which construction and backfilling operations can be properly conducted. Data on groundwater conditions are also essential for forecasting construction dewatering requirements and stability problems. Groundwater studies must consist of investigations to determine groundwater levels to include any seasonal variations and artesian conditions, the location of any water-bearing strata, and the permeability and flow characteristics of water-bearing strata.

3.3.2.2 LABORATORY TESTING. The design of any foundation is dependent on the engineering characteristics of the supporting media which may be soil or rock in either its natural state or as compacted backfill. The laboratory-testing program will furnish the engineer information for planning, designing and constructing subsurface structures. Laboratory testing programs usually follow a general pattern and, to some extent, can be standardized, but they should be adapted to particular problems and soil conditions. Special tests and research should be utilized when necessary to develop needed information. The testing program should be well planned with the engineering features of the structure and backfill in mind. Testing should be concentrated on samples from areas where significant features will be located but should still present a complete picture of the soil and rock properties. The laboratory test procedures and equipment are described in ASTM D 2487 and its references.

3.3.2.2.1 IDENTIFICATION AND CLASSIFICATION OF SOILS. The Unified Soil Classification System used for classifying soils for projects (ASTM D 2487) is a means of identifying a soil and placing it in a category of distinctive engineering properties. Table 3.1 shows the properties of soil groups pertinent to backfill and foundations. Using these characteristics, the engineer can prepare preliminary designs based on classification and plan the laboratory testing program intelligently and economically. The Unified Soil Classification System classifies soils according to their grain-size distribution and plasticity characteristics, and groups them with respect to their engineering behavior. With experience, the plasticity and gradation properties can be estimated using simple, expedient tests (See ASTM D 2487) and these estimates can be confirmed using simple laboratory tests. The principal laboratory tests performed for classification are grain-size analyses and Atterberg limits. The engineering properties in

Table 3.1 are based on "Standard Proctor" (ASTM D 2487) maximum density except that the California Bearing Ratio (ASTM D 1883) and the subgrade modulus are based on ASTM D 1557 maximum density. This information can be used for initial design studies. However, for final design of important structures, laboratory tests are required to determine actual performance characteristics, such as ASTM D 1557 compaction properties, shear strength, permeability, compressibility, swelling characteristics, and frost susceptibility where applicable, under expected construction conditions. The Unified Soil Classification System is particularly useful in evaluating, by visual examination, the suitability of potential borrow materials for use as compacted backfill. Proficiency in visual classification can be developed through practice by comparing estimated soil properties with the results of laboratory classification tests.

3.3.2.2.2 COMPACTION TESTING. Compaction test procedures are described in detail in ASTM D 1557. It is important that the designer and field inspection personnel understand the basic principles and fundamentals of soil compaction.

The purpose of the laboratory compaction tests is to determine the compaction characteristics of available backfill materials. Also, anticipated field density and water content can be approximated in laboratory compacted samples in order that other engineering properties, such as shear strength, compressibility, consolidation and swelling, can be studied. For most soils there is an optimum water content at which a maximum density is obtained with a particular compaction effort. A standard five-point compaction curve relating density and water content can be developed by the procedures outlined in ASTM D 1557. The impact compaction test results normally constitute the basis on which field compaction control criteria are developed for inclusion in the specifications. However, for some cohesionless soils, higher densities can be obtained by the vibratory compaction method (commonly referred to as maximum relative density). The required field compaction is generally specified as a percentage of laboratory maximum dry density and referred to as percent ASTM D 1557 maximum density. Water content is an important controlling factor in obtaining proper compaction. The required percentage of maximum dry density and the compaction water content should be selected on the basis of the engineering characteristics, such as compression moduli, settlement and shear strength, desired in the compacted

backfill. It should be noted that these characteristics could be adversely affected by subsequent increases in water content after placement. This situation could result from an increase in the groundwater level after construction. Density control of placed backfill in the field can be facilitated by the use of rapid compaction check tests (ASTM D 5080). A direct rapid test is the one-point impact compaction test. Rapid indirect tests, such as the Proctor needle penetration for cohesive soils or the cone resistance load for cohesionless soils, can also be used when correlations with ASTM D 1557 maximum densities have been established.

3.3.2.2.3 SHEAR STRENGTH TESTING. When backfill is to be placed behind structure walls or bulkheads or as foundation support for a structure, and when fills are to be placed with unrestrained slopes, shear tests should be performed on representative samples of the backfill materials compacted to expected field densities and water contents to estimate as constructed shear strengths. The appropriate type of test required for the conditions to be analyzed is presented in ASTM D 3080, 6528 and 4767.

3.3.2.2.4 CONSOLIDATION AND SWELL TESTING. The rate and magnitude of consolidation under a given load are influenced primarily by the density and type of soil and the conditions of saturation and drainage. Fine-grained soils generally consolidate more and at a slower rate than coarse-grained soils. However, poorly graded granular soils and granular soils composed of rounded particles will often consolidate significantly under load but usually at a relatively fast rate.

Group Symbol	Soil Type	Range of Maximum Dry Unit Weight, gm/cm ³ (pcf)	Range of Optimum Water Content, Percent	Typical Value of Compression (Percent of Original Height)		Typical Strength Characteristics			Typical Coefficient of Permeability cm ² /sec (μm ²)	Range of CBR Values	Range of Subgrade Modulus k (lb/in ²)
				A1 138 kPa (20 psi)	A1 345 kPa (50 psi)	Cohesion (as compacted) psf	Cohesion (saturated) psf	Effective Stress Envelope deg			
GW	Well graded, clean gravels, gravel-sand mixtures	2.00-2.16 (125-135)	11-9	0.3	0.6	0	0	>38	2.5×10^{-2} (5×10^{-2})	40-80	81-136 (300-500)
GP	Poorly graded clean gravel-sand mix	1.84-2.00 (115-125)	14-11	0.4	0.9	0	0	>37	5×10^{-2} (10^{-1})	30-60	68-108 (250-400)
GM	Silty gravels, poorly graded gravel-sand-silt	1.92-2.16 (120-135)	12-8	0.5	1.1	—	—	>34	$>5 \times 10^{-7}$ ($>10^{-6}$)	20-60	27-108 (100-400)
GC	Clayey gravels, poorly graded gravel-sand-clay	1.84-2.08 (115-130)	14-9	0.7	1.6	—	—	>31	$>5 \times 10^{-4}$ ($>10^{-3}$)	20-40	27-81 (100-300)
SW	Well graded clean sands, gravelly sands	1.76-2.08 (110-130)	16-9	0.6	1.2	0	0	38	5×10^{-4} ($>10^{-3}$)	20-40	54-81 (200-300)

Table 3-1

Typical Engineering Properties of Compacted Materials

Group Symbol	Soil Type	Range of Maximum Dry Unit Weight, g/m^3 (pcf)	Range of Optimum Water Content Percent	Typical Value of Compression (Percent of Original Height)		Typical Strength Characteristics			Typical Coefficient of Permeability cm/sec (ft/min)	Range of CBR Values	Range of Subgrade Modulus k (lb/in)
				A1:138 kPa (20 psi)	A1:345 kPa (50 psi)	Cohesion (as compacted) kPa (psf)	Cohesion (saturated) kPa (psf)	Effective Stress Envelope deg			
SM	Silty sands, poorly graded sand-silt mix	1.76-2.00 (110-125)	16-11	0.8	1.6	50 (1050)	20 (420)	34	2.5×10^{-6} (5×10^{-5})	10-40	21-81 (100-300)
SM-SC	Sand-silt clay mix with slightly plastic fines	1.76-2.08 (110-130)	15-11	0.8	1.4	50 (1050)	14 (300)	33	1×10^{-6} (2×10^{-5})	—	—
SC	Clayey sands, poorly graded sand-clay-silt mix	1.68-2.00 (105-125)	19-11	1.1	2.2	74 (1550)	11 (230)	31	2.5×10^{-7} (5×10^{-7})	5-20	21-81 (100-300)
ML	Inorganic silts and clayey silts	1.52-1.92 (95-120)	24-12	0.9	1.7	67 (1400)	9 (190)	32	5×10^{-6} (10^{-5})	15 or <	21-54 (100-200)
ML-CL	Mixture of inorganic silt and clay	1.60-1.92 (100-200)	22-12	1.0	2.2	65 (1350)	22 (450)	32	2.5×10^{-6} (5×10^{-7})	—	21-54 (100-200)

Table 3-1 (continued)

Typical Engineering Properties of Compacted Materials

Group Symbol	Soil Type	Range of Maximum Dry Unit Weight, gm/cm ³ (pcf)	Range of Optimum Water Content, Percent	Typical Value of Compression (Percent of Original Height)		Typical Strength Characteristics				Typical Coefficient of Permeability cm/sec (ft/min)	Range of CBR Values	Range of Subgrade Modulus k (lb/cu in)
				At 138 kPa (20 psi)	At 345 kPa (50 psi)	Cohesion (as compacted) kPa (psf)	Cohesion (saturated) kPa (psf)	Effective Stress Envelope deg				
CL	Inorganic clays of low to medium plasticity	1.52-1.92 (95-120)	34-42	1.3	2.5	86 (1800)	13 (270)	28	5 x 10 ⁻⁸ (10 ⁻⁷)	15 or <	14-54 (50-200)	
OL	Organic silts and silt-clays of low plasticity	1.28-1.60 (80-100)	33-21	---	---	---	---	---	---	5 or <	14-27 (50-100)	
MH	Inorganic clayey silts, elastic silts	1.20-1.52 (75-95)	40-24	2.0	3.8	72 (1500)	20 (420)	25	2.5 x 10 ⁻⁷ (5x10 ⁻⁷)	10 or <	14-27 (50-100)	
CH	Inorganic clays of high plasticity	1.28-1.68 (80-105)	36-19	2.6	3.9	103 (2150)	11 (230)	19	5 x 10 ⁻⁸ (10 ⁻⁷)	15 or <	14-34 (50-150)	
OH	Organic and silty clays	1.20-1.60 (75-100)	45-21	---	---	---	---	---	---	5 or <	7-27 (25-100)	

Notes: 1. All properties are for condition of Standard Proctor maximum density except values of k and CBR, which are for CESS maximum density.
2. Typical strength characteristics are for effective stress envelopes and are obtained from USBR data.
3. Compression values are for vertical loading with complete lateral reinforcement.
4. (-) Indicates that typical property is greater than the value shown. (.....) Indicates insufficient data available for an estimate.

Table 3-1 (continued)

Typical Engineering Properties of Compacted Materials

The procedure for the consolidation test is outlined in ASTM D 2435 and D 4546. The information obtained in this test can be used in settlement analyses to determine the total settlement, the time rate of settlement and the differential settlement under varying loading conditions. Consolidation characteristics are important considerations in the selection of backfill materials. The results of consolidation tests performed on laboratory compacted specimens of backfill material can be used in determining the percent compaction to be required in the specifications. Swelling characteristics can be determined by a modified consolidation test procedure. The degree of swelling and swelling pressure should be determined on all backfill and foundation materials suspected of having swelling characteristics. This fact is particularly important when a considerable overburden load is removed by excavation or when the compacted backfill with swelling tendencies may become saturated upon removal of the dewatering system and subsequent rise of the groundwater level. The results of swelling tests can be used to determine the suitability of material as backfill. When it is necessary to use backfill materials that have a tendency to swell upon saturation because more suitable materials are unavailable, the placement water content and density that will minimize swelling can be determined from a series of tests. FHWA-RD-79-51 provides further information applicable to compacted backfills.

3.3.2.2.5 PERMEABILITY TESTS. Permeability tests to determine the rate of flow of water through a material can be conducted in the laboratory by procedures described in ASTM D 2434, D 2335 and D 3152. Permeability characteristics of fine-grained materials at various densities can also be determined from consolidation tests. Permeability characteristics for the design of permanent drainage systems for structures founded below the groundwater level must be obtained from laboratory tests. The tests should be performed on representative specimens of backfill materials compacted in the laboratory to densities expected in the field. In situ material permeability characteristics for the design of construction excavation dewatering systems can also be approximated from laboratory tests on representative undisturbed samples. Laboratory permeability tests on undisturbed samples are less expensive than in situ pumping tests performed in the field; however, laboratory tests are less accurate in predicting flow characteristics.

3.3.2.2.6 SLAKE DURABILITY OF SHALES. Some clay shales tend to slake when exposed to air and water and must be protected immediately after they are exposed. The extent of slaking also governs the manner in which they are treated as a backfill material. Slaking characteristics can be evaluated by laboratory jar-slake tests or slake-durability tests. The jar-slake test is qualitative with six descriptive degrees of slaking determined from visual observation of oven dried samples soaked in tap water for as long as 24 hours. The jar-slake test is not a standardized test. One version of the jar-slake test is discussed in FHWA-RD-78-141. The slake-durability test is a standardized test that gives a quantitative description in percent by weight of material remaining intact at the conclusion of the test. Details of the test are presented in FHWA-RD-78-141.

3.3.2.2.7 DYNAMIC TESTS FOR SPECIAL PROJECTS. The dynamic analysis of projects subject to seismic or blast-induced loading conditions requires special dynamic tests on both in situ and backfill materials. Tests required for dynamic analysis include: cyclic triaxial tests; in situ density measurements; and tests to determine shear wave velocities, shear modulus, and damping.

3.3.2.2.8 IN SITU WATER CONTENT. The in situ water content, including any seasonal variation, must be determined prior to construction for materials selected for use as backfill. Natural in situ water contents will determine the need for wetting or drying the backfill material before placement to obtain near optimum water contents for placement and compaction. ASTM D 2216 discusses the test method for determining water content.

3.4 SELECTION OF BACKFILL MATERIALS. Selection of backfill materials should be based upon the engineering properties and compaction characteristics of the materials available. The results of the field exploration and laboratory test programs should provide adequate information for this purpose. The materials may come from required excavation, adjacent borrow pits, or commercial sources. In selecting materials to be used, first consideration should be given to the maximum use of materials from required excavation. If the excavated materials are deficient in quality or quantity, other sources should be considered. Common backfill having the desired properties may be found in borrow areas convenient to the site, but it may be necessary to obtain select

backfill materials having particular gradation requirements, such as filter sands and gravels, and pipe or conduit bedding materials from commercial sources.

3.4.1 PRIMARY CONSIDERATIONS. Primary considerations for borrow material sources are suitability and quantity. Accessibility and proximity of the borrow area to the jobsite should also be considered. The water contents of the borrow area material should be determined seasonally, and a source of water should be located if the natural water contents are considerably less than the required placement water content. If several sources of suitable backfill are available, other factors to be considered in selecting the borrow materials are ease of loading and spreading and the means for adding or reducing water. The need for separating or mixing soil strata from excavation or borrow sources should be considered, if necessary, to provide reasonably uniform engineering properties throughout the compacted backfill.

3.4.2 COMPACTION CHARACTERISTICS. If compaction characteristics of the major portion of the backfill are relatively uniform, problems of controlling placement of backfill will be significantly reduced since the inspector will be able to develop more rapidly the ability to recognize the adequacy of the compaction procedures. In addition, the frequency of testing for compaction control could be reduced. When available backfill materials are unusual, test sections of compacted backfill are sometimes justified to develop placement procedures and to determine the engineering characteristics to be expected in field-compacted materials.

3.4.3 WORKABILITY. An important factor in choosing backfill materials is the workability or ease with which the soil can be placed and compacted. Material characteristics that effect workability include: the ease of adjusting water contents in the field by wetting or aeration; the sensitivity to the compaction water content with respect to optimum; and the amount of compaction effort required to achieve specified densities.

3.4.4 TYPES OF BACKFILL MATERIAL. A discussion of the many types of backfill and their compaction characteristics is beyond the scope of this manual since soil types will vary on each project. However, the compaction characteristics of several rather broad categories of backfill (Table 3-1) are discussed briefly.

3.4.4.1 COARSE-GRAINED SOILS. Coarse-grained soils include gravelly and sandy soils and range from clayey sands (SC) through the well-graded gravels or gravel-sand mixtures (GW) with little or no fines (Table 3-1). They will exhibit slight to no plasticity. All of the well-graded soils falling in this category have fairly good compaction characteristics and, when adequately compacted, provide good backfill and foundation support. One difficulty that might arise with soils in this category would be obtaining good compaction of the poorly graded sands and gravels. These poorly graded materials may require saturation with downward drainage and compaction with greater compaction effort to achieve sufficiently high densities. Also, close control of water content is required where silt is present in substantial amounts. Coarse-grained materials compacted to a low relative density are susceptible upon saturation to liquefaction under dynamic loads. For sands and gravelly sands with little or no fines, good compaction can be achieved in either the air-dried or saturated condition. Downward drainage is required to maintain seepage forces in a downward direction if saturation is used to aid in compaction. Consideration may be given to the economy of adding cement to stabilize moist clean sands that are particularly difficult to compact in narrow confined areas. However, the addition of cement may produce zones with greater rigidity than untreated adjacent backfill and form "hard spots" resulting in non-uniform stresses and deformations in the structure. Cohesionless materials are well suited for placement in confined areas adjacent to and around structures where heavy equipment is not permitted and beneath and around irregularly shaped structures, such as tunnels, culverts, utilities, and tanks. Clean, granular, well-graded materials having a maximum size of 1 inch with 95 percent passing the 4.75 mm (No. 4) sieve and 5 percent or less passing the 75 Micron (No. 200) sieve are excellent for use in these zones. However, a danger exists of creating zones where seepage water may accumulate and saturate adjacent cohesive soils resulting in undesirable consolidation

or swelling. In such cases, provisions for draining the granular backfill, sealing the surface, and draining surface water away from the structure are necessary.

3.4.4.2 FINE-GRAINED SOILS OF LOW TO MEDIUM PLASTICITY. Inorganic clays (CL) of low to medium plasticity (gravelly, sandy, or silty clays and lean clays) and inorganic silts and very fine sands (ML) of low plasticity (silty or clayey fine sands and clayey silts) are included in this category. The inorganic clays are relatively impervious and can be compacted fairly easily with heavy compaction equipment to provide a good stable backfill. Soils in the CL group can be compacted in confined areas to a fairly high degree of compaction with proper water content and lift thickness control. The clayey sands of the SC group and clayey silts of the ML group can be compacted to fairly high densities. However, close control of water content is essential and sometimes critical, particularly on the wet side of optimum water content. Some ML soils, if compacted on the dry side of optimum, may lose considerable strength upon saturation after compaction. Considerable settlement may occur. Caution must therefore be exercised in the use of such soils as backfill, particularly below the groundwater level. Also, saturated ML soils are likely to be highly susceptible to liquefaction when dynamically loaded. Where such soils are used as backfill in seismic prone areas, laboratory tests should be conducted to determine their liquefaction potential.

3.4.4.3 ROCK. The suitability of rock as backfill material is highly dependent upon the gradation and hardness of the rock particles. The quantity of hard rock excavated at most subsurface structure sites is relatively small, but select cohesionless materials may be difficult to find or may be expensive. Therefore, excavated hard rock may be specified for crusher processing and used as select cohesionless material.

3.4.4.4 SHALE. Although shale is commonly referred to as rock, the tendency of some shales to breakdown under heavy compaction equipment and slake when exposed to air or water after placement warrants special consideration. Some soft shales break down under heavy compaction equipment causing the material to have entirely different properties after compaction than it had before compaction. This fact should be recognized before this type of material is used for backfill. Establishing the proper compaction criteria may require that the contractor construct a test fill and vary the water content, lift thickness, and number of coverages with the equipment proposed for

use in the backfill operation. This type of backfill can be used only in unrestricted open zones where heavy towed or self-propelled equipment can operate. Some shales have a tendency to break down or slake when exposed to air. Other shales that appear rock-like when excavated will soften or slake and deteriorate upon wetting after placement as rockfill. Alternate cycles of wetting and drying increases the slaking process. The extent of material breakdown determines the manner in which it is treated as a backfill material. If the material completely degrades into constituent particles or small chips and flakes, it must be treated as a soil-like material with property characteristics similar to ML, CL or CH materials, depending upon the intact composition of the parent material. Complete degradation can be facilitated by alternately wetting, drying and disking the material before compaction. A detailed discussion on the treatment of shales as a fill material is given in FHWA-RD-78-141.

3.4.4.5 MARGINAL MATERIALS. Marginal materials are those materials that, because of poor compaction, consolidation or swelling characteristics, would not normally be used as backfill if sources of suitable material were available. Materials considered to be marginal include fine-grained soils of high plasticity and expansive clays. The decision to use marginal materials should be based on economical and energy conservation considerations to include the cost of obtaining suitable material whether from a distant borrow area or commercial sources; possible distress repair costs caused by use of marginal material; and the extra costs involved in processing, placing, and adequately compacting marginal material. The fine-grained, highly plastic materials make poor backfill because of the difficulty in handling, exercising water-content control and compacting. The water content of highly plastic fine grained soils is critical to proper compaction and is very difficult to control in the field by aeration or wetting. Furthermore, such soils are much more compressible than less-plastic and coarse-grained soils; shear strength and thus earth pressures may fluctuate between wide limits with changes in water content; and in cold climates, frost action will occur in fine-grained soils that are not properly drained. The only soil type in this category that might be considered suitable as backfill is inorganic clay (CH). Use of CH soils should be avoided in confined areas if a high degree of compaction is needed to minimize backfill settlement or to provide a high compression modulus. The swelling (and

shrinking) characteristics of expansive clay vary with the type of clay mineral present in the soil, the percentage of that clay mineral, and the change in water content. The active clay minerals include montmorillonite, mixed-layer combinations of montmorillonite and other clay minerals, and under some conditions chlorites and vermiculites. Problems may occur from the rise of groundwater, seepage, leakage or elimination of surface evaporation that may increase or decrease the water content of compacted soil and lead to the tendency to expand or shrink. If the swelling pressure developed is greater than the restraining pressure, heave will occur and may cause structural distress. Compaction on the wet side of optimum moisture content will produce lower magnitudes of swelling and swell pressure. Expansive clays that exhibit significant volume increases should not be used as backfill where the potential for structural damage might exist. Suitability should be based upon laboratory swell tests. Additives, such as hydrated lime, quicklime, and fly ash, can be mixed with some highly plastic clays to improve their engineering characteristics and permit the use of some materials that would otherwise be unacceptable. Hydrated lime can also be mixed with some expansive clays to reduce their swelling characteristics. Laboratory tests should be performed to determine the amount of the additive that should be used and the characteristics of the backfill material as a result of using the additive. Because of the complexity of soil additive systems and the almost completely empirical nature of the current state of the art, trial mixes must be verified in the field by test fills.

3.4.4.6 COMMERCIAL BY-PRODUCTS. The use of commercial by-products, such as furnace slag or fly ash as backfill material, may be advantageous where such products are locally available and where suitable natural materials cannot be found. Fly ash has been used as a lightweight backfill behind a 7.6 m (25 ft) high wall and as an additive to highly plastic clay. The suitability of these materials will depend upon the desirable characteristics of the backfill and the engineering characteristics of the products.

3.5 PROCESSING OF BACKFILL MATERIALS. The construction of subsurface structures often requires the construction of elements of the structure within or upon large masses of backfill. The proper functioning of these elements is often critically affected by adverse behavioral characteristics of the backfill. Behavioral characteristics

are related to material type, water content during compaction, gradation and compaction effort. While compaction effort may be easily controlled during compaction, it is difficult to control material type, water content and gradation of the material as it is being placed in the backfill. Control criteria must be established prior to placement.

3.5.1 MATERIAL TYPE. Backfill material should consist of a homogeneous material of consistent and desirable characteristics. The field engineer must ensure that only the approved backfill material is used and that the material is uniform in nature and free of any anomalous material such as organic matter or clay pockets. Stratified material should be mixed prior to placement to obtain a uniform blend. Excavated material to be used as backfill should be stockpiled according to class or type of material.

3.5.2 WATER CONTENT. While water content can be adjusted to some extent after placing (but before compacting), it is generally more advantageous to adjust the water content to optimum compaction conditions before placing. Adjustment of water content can be accomplished by aeration (disking or turning) or sprinkling the material in 305 mm to 450 mm (12 to 18 in) layers prior to placing or stockpiling. If the material is stockpiled, provisions should be made to maintain constant moisture content during wet or dry seasons.

3.5.3 ENSURING GRADATION. Some backfill materials consisting of crushed rock, gravel or sand require limitations on maximum and minimum particle-size or gradation distributions. Where materials cannot be located that meet gradation criteria, it may be advantageous to require processing of available material by sieving to obtain the desired gradation.